



Chicago, Illinois
September 10-15, 2012

Exhibits Rules Highlights

Rules Governing All Exhibits Highlights

New rules revisions for IMTS 2012

XV. Conditions for Displays

E. Multi-sided signs, projection screens or logos may not face an adjacent exhibitor less than or within 10 feet (3.04 meters) of the adjacent exhibitor. This will include back walls, side panels, headers and towers. They must also not be visible from adjacent exhibitor when displayed on fabric/curtain.

XVI. Illumination

Lighting and projection must be confined within the boundaries of the booth. They should not project into other booths or into the aisles.

XVIII. Sound Devices

No live musical performances. Sound should not exceed 75 decibels and not disrupt neighbors' activities relating to normal conversation.

XXVII. Lotteries, Contests

No casino-type games are permitted.

Payment Schedule

<u>Date</u>	<u>Payment terms</u>	<u>Cancellation Credit</u>	<u>Forfeiture % Amount</u>
10/11/10	10% Deposit		100%
04/15/11	30% with contract	50%	50%
01/15/12	30% 3 rd payment	50%	50%
04/15/12	30% final payment		100%

If the cancellation or reduction is made after April 15, 2012, all payments for cancelled space are forfeited.



Chicago, Illinois
September 10-15, 2012

Rules Governing All Exhibits

Definitions

AMT, for the purposes of these rules, means AMT – The Association For Manufacturing Technology and its authorized agents and representatives acting within the scope of their authority. The “Show” as used in these rules means the International Manufacturing Technology Show to be held in Chicago, Illinois, U.S.A., September 10-15, 2012, inclusive.

“EXHIBITOR,” as used in these rules, means any person or company exhibiting in the Show, its representatives, agents and employees at the Show.

The decisions of AMT in interpreting these rules shall be final.

I. Eligibility

- A. The following products are eligible for exhibition:
 - 1. Manufacturing machinery, which for this purpose is defined as power-driven machines, used to shape or form materials used in manufacturing by cutting, impact, pressure, electrical techniques, or by a combination of these processes.
 - 2. Equipment and devices accessory to manufacturing machinery, such as assembly equipment, materials handling equipment, controls, motors, power transmission equipment, instrumentation, hydraulic and pneumatic components, lubricants and coolants, testing equipment, tools, chucks, attachments, etc.
 - 3. Welding machines and induction and thermal hardening and heat-treating machines and equipment, and accessories.
 - 4. Services and publications for manufacturing.
- B. The following companies are eligible to exhibit:
 - 1. Companies under whose name eligible products are manufactured or sold.
 - 2. Distributors who represent manufacturers of eligible products nationwide in the United States, as identified in the official space application form. However, in the case of exhibits by distributors of the eligible products of more than one manufacturer, the directory listing shall bear the names of all manufacturers of the products exhibited.
 - 3. Publishers or providers of services in the manufacturing technology field.
- C. Exhibits will not be grouped by national origin into single booths except in the case of governments’ foreign trading organizations.
- D. AMT reserves the right to deny exhibit space to any company or product, and eligibility to exhibit shall generally be a continuing requirement as of the date of the opening of the Show. However, companies and distributors who are eligible to exhibit as of the date the final space payment is due or paid shall be protected from disqualification under this rule or Rule VIII, due to subsequent bona fide changes in business relationships.

II. Limitation of Liability Indemnification

- A. EXHIBITOR waives all claims of every kind against AMT, its directors, officers, members, agents and employees including, without limitation, all claims for damages based on personal property damage, destruction, loss or theft, personal injury, cancellation of the Show, failure or refusal to provide space for any exhibit, preventing the display, operation, removal or dismantling of any exhibit, any other act or failure to act of AMT.

- B. EXHIBITOR agrees to indemnify and save AMT harmless from claims by EXHIBITOR's agents or employees or by any other person, arising out of any act or omission in any way related to EXHIBITOR's participation in the Show, whether negligent or not.
- C. In the event of cancellation or disruption of the Show for any cause, AMT shall have the right to retain such part of EXHIBITOR's space payments as may be required to reimburse AMT for expenses incurred in connection with the Show.

III. Installation and Removal of Exhibits

A schedule of dates for arrival and removal from the exhibit halls of exhibit material shall be announced. Any expenses caused by failure to conform to these schedules shall be paid by EXHIBITOR.

IV. Dates and Hours of Show

All exhibits shall be completely installed and ready for display no later than 2:00 p.m., Sunday, September 9, 2012. Sales and distributor orientation may be conducted on Sunday, September 9, 2012 between 9:00 a.m. and 6:00 p.m.

Show dates: Monday, September 10 – Saturday, September 15, 2012

Show daily hours:

- Lakeside Center..... Exhibitor: 7:00 a.m. – 5:30 p.m. – Attendee: 9:00 a.m. – 5:00 p.m.
 North & South Halls..... Exhibitor: 8:00 a.m. – 6:30 p.m. – Attendee: 10:00 a.m. – 6:00 p.m.
 West..... Exhibitor: 7:00 a.m. – 5:30 p.m. – Attendee: 9:00 a.m. – 5:00 p.m.

V. Dismantling of Exhibits

No exhibits shall be dismantled or removed, in whole or in part, prior to close of show, Saturday, September 10, 2012, or such other time as designated by AMT. AMT may prevent the removal or dismantling of any exhibit before the time of closing.

VI. Payment Schedule – Cancellation or Reduction of Space – Notice of Change of Plans

- A. Payments for space are due in four installments as follows:
1. 10% due with the return of space application
 2. 30% due April 15, 2011 (with return of contract)
 3. 30% due January 15, 2012
 4. 30% due April 15, 2012
 5. If the EXHIBITOR returns his contact after April 15, 2012, the contract must be accompanied by an amount equal to the total of all installment payments accrued as of the date that EXHIBITOR signs the contract. (For example, a contract submitted on January 15, 2012, must be accompanied by an amount equal to the total of the first three installment payments.)
- B. Space payments are non-refundable. In the event that EXHIBITOR fails to use all or part of any space contracted for, no part of any payment hereunder with respect to unused space will be returned to EXHIBITOR. However, a percentage of the forfeited payments can be applied to IMTS 2014 for cancellations made between April 15, 2011, and April 15, 2012, based on the following schedule:

Date	Payment Terms	Cancellation Credit%	Forfeiture Amount
10/11/2008	10% Deposit		100%
04/15/2011	30% With Contract	50%	50%
01/15/2012	30% 2 nd Payment	50%	50%
04/15/2012	30% Final Payment		100%

If the cancellation or reduction is made after April 15, 2012, all payments for cancelled space are forfeited.

- C. If at any time between March 1, 2011 and June 30, 2012 an EXHIBITOR determines not to use some or all of the space for which he has contracted, he shall give prompt written notice to AMT of his change in

plans, so that AMT may reallocate the unused space pursuant to Rule XXXI as may be necessary or appropriate to the satisfactory arrangement and conduct of the Show. Failure to furnish the notice required by this rule shall subject an EXHIBITOR to a surcharge of 25 percent of cost of the space not used.

VII. Rejected Display

Each exhibit shall be admitted to the Show and shall remain at the Show from day to day, subject to EXHIBITOR's continued compliance with these rules. AMT reserves the right to reject, eject or prohibit any exhibit or its operation in whole or in part, or to eject or refuse to admit EXHIBITOR or his representative, for failure to comply with these rules or with any instructions issued by AMT or for conduct deemed detrimental to the best interests of the Show. If an exhibit is rejected, ejected or prohibited for violation of these rules, or EXHIBITOR or his representative is ejected or refused admission pursuant to this paragraph, EXHIBITOR shall have no recourse against AMT and no portion of the space payment shall be refunded.

VIII. Subleasing and Identifying Other Products and Services

A. EXHIBITOR shall not sublet any part of his space. However, an EXHIBITOR may use his space to exhibit any eligible products: (i) manufactured or sold in his own name, (ii) manufactured or sold by any company controlled by or under common control with EXHIBITOR, (iii) manufactured or sold by a joint venture in which he participates, or (iv) produced or sold pursuant to a manufacturing or sales license. Comparisons or comparative tests involving actual products or equipment other than those defined immediately above as "eligible products" will not be permitted unless the manufacturer of the product or equipment concerned shall have given his prior or written consent.

B. EXHIBITOR shall not exhibit, offer for sale, give as a premium, or furnish literature about any other products or services except where AMT determines that such activities are required for the proper demonstration or operation of EXHIBITOR's displays. In any case, identification of such articles or services shall be limited to the regular nameplate, imprint, or other identification, which in standard practice appears normally on the articles or in connection with the services. EXHIBITOR shall not permit persons other than its own representatives (including those of any corporate affiliate, joint venture partner or licensee), representatives of AMT, or of officially designated labor or service sources to use its booth for any purpose.

IX. Admission and Identification

Admission of EXHIBITOR's representatives and visitors to the exhibit halls shall at all times be controlled solely by AMT. EXHIBITOR's representatives shall wear identifying badge as provided by AMT throughout the Show hours, installation and dismantling periods.

X. Booth Representatives

EXHIBITOR may be represented in its booth by direct representatives (employees who are scheduled for actual booth work) and distributor representatives.

XI. Admission During Non-Show Hours

EXHIBITOR's representatives, distributors, and the working press shall be permitted to enter the Show two hours before the scheduled opening. Representatives of EXHIBITORS, distributors, and the working press who require earlier entrance may obtain special permission at the Show Management offices on the previous day by 2:00 p.m.

EXHIBITOR's representatives, distributors, and members of the press shall be permitted to remain in the Show 30 minutes after the scheduled closing of each day. Special permission must be obtained at the Show Management office in advance if an extension of time is needed.

XII. Photography

During the move-in and move-out periods, EXHIBITOR's personnel, agents or other representatives acting on its behalf will be limited to picture taking within its own booth(s). During the exhibition, each EXHIBITOR has the prerogative of establishing its own policy on picture taking in its booth during Show hours and notifying visitors of the policy. During the exhibition no pictures may be taken of exhibits when the Show is closed in the respective exhibit halls without permission from Show Management. Anyone violating these rules will be ejected from the Show floor and must surrender his/her admission credentials.

XIII. Attire

EXHIBITOR's representatives wearing distinctive costumes, uniforms or shopcoats, or carrying banners or signs separately or as part of their apparel, shall not be permitted to appear in the Show, except in their own booths or in their ordinary passage to and from such booths.

Show management reserves the right in its sole discretion to deny admission to any EXHIBITOR or attendee whose dress or conduct is deemed to be inappropriate.

XIV. Labor and Services

EXHIBITOR shall employ only labor made available from sources officially designated by AMT for the installation, maintenance and dismantling of its exhibit, and shall use only the service organizations officially designated by AMT for all services in connection with the installation, maintenance, cleaning and dismantling of exhibits and in connection with the operation of projection devices.

XV. Conditions for Displays

All special exhibit units shall be fabricated in accordance with these rules and such additional instructions as may be issued from time to time by AMT. All display material made in the United States shall bear appropriate A.F.L.-C.I.O. union labels.

A. EXHIBITOR may submit sketches of and specifications for proposed exhibits. AMT shall advise the EXHIBITOR regarding the acceptability of its proposed exhibit under show rules, but reserves the right to require changes before or after the exhibit is installed.

B. Height restrictions for booth construction – see attached addendum. (Please note upper limit on booth construction in relation to ceiling height.)

C. The use of viewing platforms is permitted. Elevated platforms shall have guardrails and toe boards so as to minimize injury to persons working on or below such platforms. Railings shall consist of a top rail, intermediate rail, and posts, and shall have a vertical height of at least 42 inches (106.68 cm) from the upper surface of the top rail and the floor. The intermediate rail shall be approximately halfway between the top rail and the floor. Openings between the top rail surface and any other surface, such as the intermediate rail or toe boards, shall not exceed 19 inches (48.26 cm). Toe boards 4 inches (10.16 cm) high shall be installed on each platform unless the space between the top rail and platform floor is enclosed with some type of material (such as Plexiglas) that provides protection from falling objects to persons working or walking below the platform.

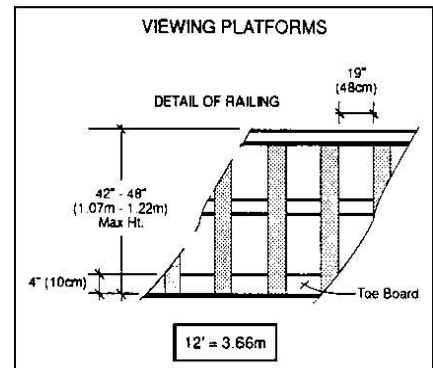

Stairways leading to the viewing platform shall comply with OSHA regulations 1910.24 (fixed industrial stairs) and 1910.23 (guarding floor and wall openings and holes). Applicable subsections of 1910.24 are: (a) application of requirements, (c) stair strength, (e) angle of stairway rise, (f) stair treads, (h) railings and handrails and (j) open risers. Applicable subsections of 1910.23 are: (d) stairway railings and handrails and (k) open risers. Applicable subsections of 1910.23 are: (d) stairway railings and guards and (e) railings, toe boards, and cover specifications. All multi-level exhibits with access via stairways or ramps to a second level require the approval of the AMT Exhibitions Department and must follow Chicago Fire Department Codes. Full detail exhibit plans must be submitted to the Exhibitions Department by July 1, 2012.

Any violations of these rules may cause the use of the platform to be discontinued.

D. Machines shall be displayed as much as possible in positions comparable to their actual installation in shops, and shall not be mounted on pedestals, platforms, or other height-increasing devices, except turntables, which shall be limited to a height of 18 inches (45.72 cm). However, skids of normal size may be left under machines when conditions require, and machines may be supported above the floor in order to avoid cutting a pit for part of the machine. The space occupied by machinery and equipment shall not exceed 60 percent of the total exhibit space, and operating equipment shall be at least three feet (.914 meter) from any aisle. Non-operating machines and displays must be set back 12 inches (30.48 cm) from the aisle line of the booth. AMT shall have the final approval for equipment placement.

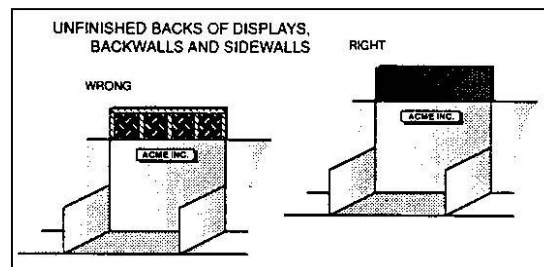
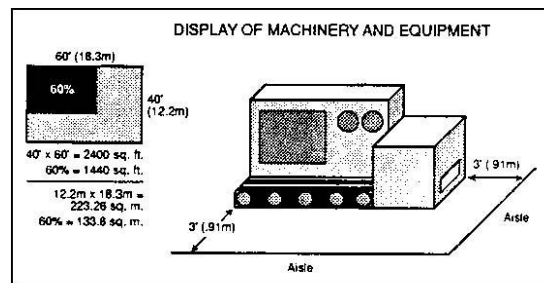

E. Multi-sided signs, projection screens or logos may not face an adjacent exhibitor less than or within 10 feet (3.04 meters) of the adjacent exhibitor. This will include back walls, side panels, headers and towers. They must also not be visible from adjacent EXHIBITOR when displayed on fabric/curtain.

Any signs with unfinished or unpainted backs must be draped, and not exceeding 24 x 24 inches (60.96 x 60.96 cm), may be placed directly against machine. EXHIBITOR shall not display signs referring to the products of another company other than an affiliated company or other EXHIBITOR. Signs stating that a machine on exhibition has been sold are prohibited. Should the wording or appearance of any sign in EXHIBITOR's booth be deemed by AMT to be contrary to the best interests of the Show, EXHIBITOR shall make such changes as requested by AMT.

Hanging company identification signs are permitted in all halls with Show Management and McCormick Place approval. Drawings must be submitted to Show Management for approval by July 1, 2012. Any hanging sign weighing more than 500 lbs must include a signed and stamped (current to 2012) certificate from a licensed structural engineer which attests to the actual hanging material weight, structural integrity and the method of support for the sign. Hanging company identification signs must be a minimum of 16 feet from floor to bottom of sign.

F. Fabric floor coverings, linoleum, tile and safety mats may be placed on booth floors. All flammable materials must be flameproof (See Rule XXIV).

G. LASER SAFETY

Exhibits including lasers or laser systems shall comply with all applicable safety standards including: 1) the guidelines provided in the American National Standard, "Safe Use of Lasers" – ANSI Z136.1-2007 (for a copy please phone ANSI at (212) 642-4900); 2) "Safety Requirements for Machine Tools Using Lasers for Processing Materials" – ANSI B11.21-2006 (for a copy please phone AMT at (703) 827-5266); 3) the Federal Regulations, 21 CFR 1040.10 and 1040.11 of the Radiation Control for Health and Safety Act of 1968 (for information on Federal Regulations, which are enforceable by the Food and Drug Administration, EXHIBITORS should call (301) 443-4874); 4) any other applicable standard. For more information, contact AMT's Safety Director at (703) 827-5211.

H. VENTING EXHAUST INTO ADJACENT BOOTHS

All air conditioners, air handlers and HVAC systems used in any enclosed office area, conference, meeting and/or closing room must be vented to the interior of the booth and must be equipped with (1) a vertical air deflector for exhausted air and (2) sound reduction materials to decrease noise. Exhausted air must be directed upwards and may not be directed into any adjoining booth, aisles, walkways or a common back wall. EXHIBITORS using any type of air conditioning or HVAC system must submit a detailed drawing and capacity rating of the proposed system to AMT by July 1, 2012.

I. **STORAGE OF ANY KIND IS FORBIDDEN**

Storage of any kind is forbidden inside the display area, behind the back drapes, or beyond the display wall. All cartons, crates, containers, packing materials, etc., which are necessary for repacking must be labeled with "EMPTY" stickers and removed from the show floor. All unwanted containers and refuse should be placed in the aisle directly in front of the exhibit. Only a one-day supply of operational and advertising material may be stored inside the exhibit. EXHIBITORS dispensing matches are not allowed to store them in their booth overnight – unless they are placed in enclosed metal containers.

XVI. Illumination

Lighting and Projection must be confined within the boundaries of the booth and should not project into other booths or into the aisles.

XVII. Smoking is Prohibited

Smoking is prohibited except in designated areas.

XVIII. Sound Devices

No live musical performances. Sound produced by other means (See Rule XIX) should not exceed 75 decibels and not disrupt neighbors' activities relating to normal conversation. Machines are exempt from second rule.

XIX. Movies-Slides-Television

EXHIBITOR may project slides, motion pictures, last imaging and television images within its own booth, up to the height limitations for displays specified in Rule XV, provided that projection equipment, screens and sound equipment shall be located so that they are not objectionable to neighboring exhibitors and viewers do not obstruct aisles. Plans or sketches for all projections must be submitted to AMT by July 1, 2012. AMT reserves the right to curtail any sound device. EXHIBITOR assumes responsibility for compliance with union requirements relating to projection equipment and sound devices.

XX. Noise

EXHIBITOR shall cooperate in eliminating or reducing as much as possible the noise caused by operation of machines. Enclosures are required for equipment used in high-speed metal forming and metal cutting operations. Noisy or obstructive work during the open hours of the Show is prohibited. Displays involved noise that tends to interfere with ordinary conversation in adjacent booths shall be subject to such restrictions as to the location, frequency and other conditions of operation as AMT in its discretion may impose.

XXI. Guarding of Robots

- A. Adequate fencing and/or shielding of all robot demonstrations shall be provided to prevent attendees from contacting the robot and/or its arc of movement by reaching over, under or around such protection.
- B. Robot demonstrations shall be supervised at all times. When the robot is not being demonstrated, it must be deactivated in a foolproof manner so that unauthorized personnel cannot activate it.
- C. Positive stops shall be built into each robot to prevent swing of its arms or movement into aisles and/or unguarded booth space.
- D. A check should be made to determine stability, particularly of those robots operating with high columns, and any unstable condition must be corrected.

XXII. Electrical Wiring

Electrical wiring shall conform to the National Fire Protection Association NFPA 79 Electrical Standard for Industrial Machinery 1979 Edition or superseding standards and the Chicago Electrical Code. Wires laid across floors shall be guarded by wood, metal or other acceptable covers. All wiring for machines and displays must include one wire for ground.

XXIII. Safety

EXHIBITOR shall comply fully with the “Health and Safety Rules of Illinois” issued by the Industrial Commission of Illinois, 160 N. LaSalle Street, Chicago, IL 60602, and with all applicable rules and regulations of the Chicago Fire Department. No vehicles, manual or powered, shall be operated anywhere in the exhibit halls during the open hours of the Show. Any exhibited vehicle shall only have one gallon of fuel in the gas tank and vehicle battery must be disconnected.

XXIV. Flammable Material – Heating Devices

No flammable materials, as defined in the rules and regulations of the Chicago Fire Department, including decorative material and machine covers, shall be permitted within the Show area or within EXHIBITOR’s booths. In connection with each fabric used in a booth, EXHIBITOR shall have, as required by the rules and regulations of the Chicago Fire Department, an affidavit establishing that it has been flame proofed, the date of the flame proofing, the type of chemical used, the process employed and the name and address of the processor.

Gas or oil furnace shall not be used in heat blanks or slugs for demonstrating forging machines. Induction heaters must be approved by the Chicago Fire Department.

EXHIBITOR shall make certain that fire hose cabinets, alarms and extinguishers within its booth are visible and accessible at all times. EXHIBITOR shall have readily available within its booth one 10-pound dry chemical-type fire extinguisher for each 2,500 sq. ft. (232 sq. meters) of booth space or fraction thereof.

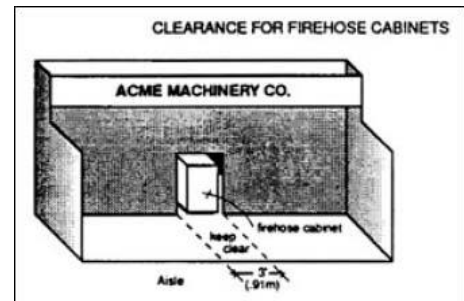

XXV. Removal of Chips (Swarf) – Delivery of Materials

Finished work and chips (swarf) shall be removed each day, only after the Show’s closing time, and materials shall be delivered only during non-show hours.

XXVI. Damage to Buildings

EXHIBITOR shall surrender the space occupied by him in the same condition as it was at the commencement of his occupation, normal wear excepted, and shall be fully liable for the cost of restoring the space to its former condition if he does not comply with this provision. EXHIBITOR shall not fasten machines or equipment to the floor by drilling into floor level or by use of adhesives, or sink machines below floor level. To make special provision for stabilizing machines, EXHIBITOR is required to obtain prior written permission from the exhibit hall management. If such permission is granted, all expenses involved shall be borne by the EXHIBITOR.

All cost for removing adhesive-backed, pressure-sensitive stickers and labels from floors, columns, walls, signs, other booths, etc., – anywhere in the exhibit halls – will be charged to the EXHIBITOR whose product they advertise.

XXVII. Lotteries, Contests

No casino-type games are permitted.

XXVIII. Distribution of Literature, Samples, Souvenirs, Food, Drink, Etc.

Samples, souvenirs, shopping bags, catalogs, pamphlets, publications, etc., shall not be distributed except from within EXHIBITOR’s booths and in accordance with the provisions of Rule XXIX.

Adhesive-backed, pressure-sensitive stickers and labels shall not be distributed on Show site. Violations of this rule shall be deemed conduct detrimental to the best interests of the Show and will also subject the EXHIBITOR to any cleaning and repair charge incurred to remove them from floors, walls, columns, other

booths, etc. Any food or beverage items distributed by EXHIBITORS to attendees must be purchased and supplied by McCormick Place Food Services.

XXIX. Obstruction of Aisles or Nearby Booths

Any demonstration, live performance or other activity that results in obstruction of aisles or that prevents ready access to a neighboring booth shall be suspended as AMT in its discretion may specify.

XXX. Resolution of Disputes

AMT shall have the right, but not the obligation, to resolve disputes or disagreements between EXHIBITORS, or between EXHIBITORS and official contractors or labor unions. In the event of a dispute or disagreement final resolution shall be binding on the EXHIBITOR.

XXXI. Relocation of Exhibits

AMT reserves the right to relocate exhibits in a space other than the one specified in the contract if, in its judgment, such relocation is necessary or appropriate to the satisfactory arrangement or conduct of the Show. No relocation shall be made, however, without affording EXHIBITOR full opportunity to indicate a preferred substitute location, but any decision by AMT with respect to relocation shall be final and shall not relieve EXHIBITOR of any obligation under this contract.

XXXII. Free On-Site Services

Companies wishing to provide complimentary services (e.g. tooling, tool sharpening, coolants, oil, transportation, and other services related to the Show) must be IMTS 2012 EXHIBITORS. AMT reserves the right to deny exhibit space to any company or product that is not applicable to the Show or its EXHIBITORS.

XXXIII. Additions and Amendments of the Rules

AMT may from time to time issue such additional rules as it deems necessary for the orderly presentation of the Show. Any rule may be amended at any time by AMT provided that such amendment shall not substantially diminish the rights or increase the liability of EXHIBITOR.

In the case of misunderstanding in translation, the English version shall be the official interpretation.

XV. Conditions for Displays
B. Height Restrictions for Booth Construction

	South	North	Lakeside Center	West
Island	Ceiling: 40 ft. Restrictions: Exposed backwalls have no restrictions except backside over 8 ft. must be finished.	Ceiling: 18 – 40 ft. Restrictions: Exposed backwalls have no restrictions except backside over 8 ft. must be finished.	Ceiling: 47 – 50 ft. Restrictions: Exposed backwalls have no restrictions except backside over 8 ft. must be finished.	Ceiling: 40 ft. Restrictions: Exposed backwalls have no restrictions except backside over 8 ft. must be finished.
Peninsula/Corner	Ceiling: 40 ft. Restrictions: Exposed backwalls have no restrictions except backside over 8 ft. must be finished.	Ceiling: 18 - 40 ft. Restrictions: Exposed backwalls have no restrictions except backside over 8 ft. must be finished.	Ceiling: 47 - 50 ft. Restrictions: Exposed backwalls have no restrictions except backside over 8 ft. must be finished.	Ceiling: 40 ft. Restrictions: Exposed backwalls have no restrictions except backside over 8 ft. must be finished.
In-Line: 300 sq. ft. or larger*	Restrictions: Exposed backwalls have no restrictions except backside over 8 ft. must be finished.	Restrictions: Exposed backwalls have no restrictions except backside over 8 ft. must be finished.	Restrictions: Exposed backwalls have no restrictions except backside over 8 ft. must be finished.	Restrictions: Exposed backwalls have no restrictions except backside over 8 ft. must be finished.
In-Line: Less than 300 sq. ft.*	Restrictions: Exhibit must remain @ 4 ft. for first 5 ft. to aisle. This rule applies only when 10 ft. to 12 ft. deep booths adjoin each other. This rule may be waived by mutual consent of adjoining exhibitors. Exposed backwalls have no restrictions except backside over 8 ft. must be finished.	Restrictions: Exhibit must remain @ 4 ft. for first 5 ft. to aisle. This rule applies only when 10 ft. to 12 ft. deep booths adjoin each other. This rule may be waived by mutual consent of adjoining exhibitors. Exposed backwalls have no restrictions except backside over 8 ft. must be finished.	Restrictions: Exhibit must remain @ 4 ft. for first 5 ft. to aisle. This rule applies only when 10 ft. to 12 ft. deep booths adjoin each other. This rule may be waived by mutual consent of adjoining exhibitors. Exposed backwalls have no restrictions except backside over 8 ft. must be finished.	Restrictions: Exhibit must remain @ 4 ft. for first 5 ft. to aisle. This rule applies only when 10 ft. to 12 ft. deep booths adjoin each other. This rule may be waived by mutual consent of adjoining exhibitors. Exposed backwalls have no restrictions except backside over 8 ft. must be finished.

Note:

- Any exhibit above a 16 ft. height must submit drawings to AMT/Show Management for approval. (Section XV, Paragraph C)
- Signs to be hung from the ceiling must be approved by Show Management. (Section XV, Paragraph E)
- All hanging signs must be a minimum of 16 ft. from floor to bottom of sign. (Section XV, Paragraph E)